

## INTRODUCTION

The EK60 evaluation kit is designed to provide a convenient way to breadboard design ideas for the PA78EU power operational amplifiers. The EVAL60 evaluation board is pre-wired for all required and recommended external components including the ones for power supply bypassing, compensation and current limiting. The EVAL60 also includes a breadboard area for constructing your application circuit with provisions for a pre-amplifier to drive the PA78 inputs.

## PARTS LIST

Apex Part #	Description	Quantity
HS27	Heatsink, Apex	1
EVAL60	PC Board, Apex	1
TW12	Thermal Washer, Apex	1 Box
OX7R105KWN	1 uF Cap 3530B105K501N Novacap, <b>200V Breakdown</b>	2
140-500N5-330J	33pF Cap CDR-500N5-330KS XICON	1
146510CJ	BNC Connector	3
MS02	Socket Strip	1 bag
MS11	Socket Strip	1 bag

## EK60 SCHEMATIC

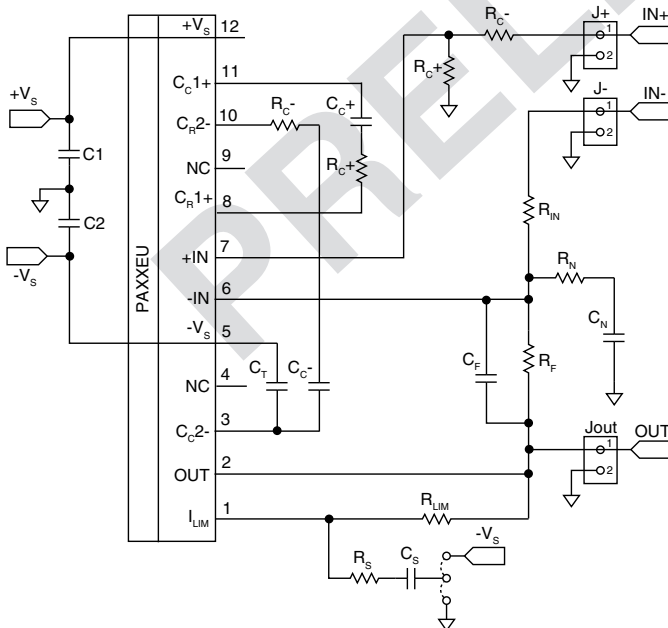

Jumper Cs to GND or -Vs for snubber if needed.  
**PACKAGE TAB CONNECTED TO STABLE REFERENCE**  
**Breakdown voltage of C1 & C2 is 200V max.**

## ASSEMBLY

During assembly refer to Figure 1 and Figure 2.

- Solder surface mount ceramic capacitors C4 and C5 on the DUT side of the board.
- Add components for compensation (CC-, CC+, RC- and RC+) based on the closed loop gain and capacitive load. Add the current limit resistor (RLIM) based on load requirements (a minimum value of 4.5 ohms should be used to protect the PA78 internal output devices). It is recommended to use MS02 sockets for the components for quick component changes on the board. Add 33pF capacitor (CT) between DUT pins 3 and 5.
- While developing your application circuit you will probably want to use the mating socket strip. Use the MS11 socket strip for mounting the PA78 EU. Clip off the strip after the 12th position. Insert the strip into the circuit board on the DUT side and solder one pin on the reverse side. Check whether the mating socket strip is fully seated against the circuit board and then solder the remaining pins. Insert the amplifier fully into the socket strip, noting the pin 1 location on the amplifier and the circuit board.
- For high power applications (see PA78EU datasheet for SOA considerations) mount the heat sink (HS27) in the outlined area on the circuit board.
- If a heat sink is used, position the thermal washer behind the amplifier in such a way that the hole on the washer coincides with the hole on the tab and the heat sink.
- For high slew rate performance connect the heat tab to a stable reference (see PA78U datasheet for details).**
- Install the banana jacks for P1 (+Vs), P2 (-Vs) and P3 (GND) as shown in figure 1 and 2. There are provisions for two extra banana jacks (P4 and P5) and can be used if desired for external connections.

Figure 1: PCB Layout

